



Dynamics of Social Capital among Irrigation Water Users in Rural Sindh Province of Pakistan

Javed M. Sheikh¹, Habibullah Magsi^{1*}, Asnarulkhadi Abu-Samah², G. Mujtaba Khushk¹,
Naeem A. Qureshi¹

¹Faculty of Agricultural Social Sciences, Sindh Agriculture University Tandojam, Pakistan

²Department of Social and Development Sciences, Faculty of Human Ecology, University Putra Malaysia

ABSTRACT

Social capital resides in interactions and refers to social resources and network structure. It develops trust, reciprocity and functions as bonding material to provide long term and sustainable results, however, fluctuates spatially and culturally. In connection with, the article attempted to reveal the various levels of social capital between farmers in participatory irrigation management, via a trust, solidarity and networks, and also supported by the theoretical perceptive. Consequently, quantified data were gathered from 457 irrigation water users of rural Sindh province, using multi-stage cluster sampling, and analyzed through SPSS (Software Package for Social Sciences) and AMOS (Analysis of Moment Structures) software. This paper reports the significant results regarding social capital in the area, which reflects in the form of reciprocity of irrigation water by the respondents. In contrast, the majority of the farmers were lacking linking social capital which must be reviewed by the policymakers for the sake of rural development.

Keywords: Social capital; community development; water management; Pakistan

1. INTRODUCTION

Social capital is a resource that can be developed (Jochum, 2003) through social relationships (Kenny, 2010), therefore, it resides in the interaction (Woolcock, 2001), and refers to the capability of people to make effort with each other in groups (Fukuyama, 2001). Social capital depends upon the explicit norms of behavior, set of connections and groups (De Silva et al., 2007), and operates at the individual, community and institutional levels (Shan et al., 2014). It is a sociological notion which could be interchanged with the network structure and social resources (Magsi and Torre, 2012; Seibert et al., 2001), and

supposed to the heart of social relations. Social capital can also be resembled with a deal in social relations with projected returns (Berzina, 2011), therefore, it can be drawn on, increase or depleted (Jochum, 2003). Social capital refers to the values and linkages that develop trust, reciprocity and cooperation for making joint plans for public welfare (Christoforou, 2012). Therefore, Hawkins and Maurer (2012) phrased the social capital as “intellectual currency” that promotes co-operation between individuals and encompasses qualities like sincerity, commitments, reliable performances, reciprocity, etc. (Fukuyama, 2001). Leana and Buren (1999) indicated the social capital as an organizational asset and Gertler et al. (2006)

*Corresponding to: hmagsi@sau.edu.pk

publicized it as the capital of the poor. As a result, Jackson (2013) optimistically declared the social capital as “the way to economic development” if positively utilized.

Social capital is interrelated with other forms of capitals (Berzina, 2011) and implies for a public good (Castagna et al., 2012). It offers greater innovation results (Eklinder-Frick et al., 2012) that helps in the rising well-being of a community (Rudd, 2000), leads to economic development (Giorgas, 2007), used for poverty eradication (Dietlind and Hooghe, 2003), and have positive impacts even on the academic achievements of the students (Dufur et al., 2013). The benefits of social capital could also be easily appeared in the business process (Mačerinskienė and Aleknavičiūtė, 2011) that leaves positive impacts on the job standing (Wu, 2008), and can also be utilized for the conflict resolutions during the process (Marsden and Oakley, 1998). Hence, social capital has the ability to produce both tangible and intangible benefits even in well developed countries (Klein, 2013). Consequently, true application of social capital could align the process of development (Marsden and Oakley, 1998), mainly encircled by the economics, sociology and management constituencies (Mohsenzadeh, 2011).

Previous literature is sufficient to make a judgment that social capital can generate considerable benefits in participatory irrigation management (Howgate and Kenyon, 2009), and collaborative approaches help to develop social capital in facilitating the integrated water management activities (Benham et al., 2012; Saied et al., 2013). In this regard, Uphoff (2001) conducted a study in Srilanka and reported that effective cooperation between farmers in the equitable sharing of scarce water produced unexpected rice production when there was an acute shortage of irrigation water and government officials had totally raised their hands from evenhanded crop production. In the similar fashion, Bengtsson (2010)

suggested that social bonds can significantly contribute to rural development, poverty alleviation and sustainable growth. The same as, Dahal and Krishna (2008) attempted a research in the Philippines, and concluded that participatory management of natural resources leads to trust, group solidarity and networking of a homogeneous community of indigenous peoples that contribute to positive impacts in the study area. For that reason, it is well thought-out as a positive feature that yields a flow of benefits, in the shape of collective action to manage a common resource and enhance the skills of villagers (Grootaert and Bastelaer, 2002), encourages cooperation in which trust can be fostered within the community members (Coleman, 1998; Fukuyama, 2001; Putnam, 1993), and also helpful in promoting new ideas like farmer-to-farmer extension services as advocated by Evelyne and Franzel (2014). At last, social capital is largely utilized for the conflict resolutions (Marsden and Oakley, 1998), as the cooperation of communities and landowners is vital during a flood situation (Howgate and Kenyon, 2009).

Violence associated when water is derived from mismanagement (Saeid, 2012) and lack of social capital during a participatory process (Uphoff, 2001). Therefore, the social capital also functions to address the institutional obstacles of distribution inequalities and tackle the insecurity, which is a hot spot identified by the researcher, however, the water scarcity greatly threatens the livelihoods of the farmers (Sheikh et al., 2015b). Furthermore, the agricultural shortage cause increased in food price, which adversely affect the poor communities of both rural and urban vicinities (Kugelman and Hathaway, 2009). Therefore the experience in other countries suggested that apart from the effective irrigation and drainage system, giving farmers a decisive role in the water management, build confidence in the farmers, which in turn empower and sustain the

farming communities to ensure the proper benefits from water management (FAO, 2003). While we know that the greater implication of social capital during participation in water management activities to gain benefits, the area is remarkably insufficient from the literature. In addition, social capital is a multidimensional term (De Silva et al., 2007) and different cultures produce social capital differently (Dietlind and Hooghe, 2003), so it could be resulted in various levels and types at different geographical locations. Therefore, in order to bridge the gap, the researcher focused on examining the level of social capital that could give a clearer picture at the micro level of irrigation water users' ties in Sindh province of Pakistan.

2. THEORETICAL FRAMEWORK

Characteristics of the community/targeted group, a community-run watercourse association refers the bottom-up approach and homogeneity, therefore, structural social capital, relational/bonding social capital and linking social capital were conceptualized to make the study comprehensive and widespread (Sheikh et al., 2015a). However, an in-depth theoretical perspective about the social capital is available in the article "Identifying Sources of Social Capital among the Farmers of the Rural Sindh Province of Pakistan" published by the same author in an impact factor journal and cited above.

3. MATERIALS AND METHODS

In order to avoid the repetition and following plagiarism policy, it is advised to browse articles (Sheikh et al., 2015a) for in depth comprehension about theoretical framework, measurement of variables and research methodology. The study is in line with qualitative approach and cross-sectional

survey was conducted in Sindh province of Pakistan, where a multi-stage cluster sampling method was adopted to collect the data from 457 respondents/irrigation water users.

Confirmatory Factor Analysis (CFA) is generally part of Structural Equation Modeling (Darlington, 2002), but also used to construct validation, evaluation of measurement invariance and convergent validity (Brown and Michael, 2010). For the purpose, CFA was applied to discover the construct reliability, discriminant and convergent validity of the variables as reflected in Fig. 1. In this regard, the items which did not meet the cutoff point of 0.5 (Yusoff, 2011), and disturb in achieving correlation of less than 0.85 were discontinued. The correlation between two factors if close to one or minus one, it is considered to have poor discriminant validity, however, a correlation of less than 0.85 is considerably accepted (Kenny, 2012). For this study, trust (bonding social capital) had 10 items, but it was reduced to 04 items with AVE=0.6. Group solidarity (structural social capital) had 17 items, however, after conducting first and second order CFA, only 5 items with AVE=0.5 were stabled. Similarly, networking (linking social capital) was measured with 09 items, but it remained only 4 items at the end with AVE=0.5.

The results generated by AMOS shows that the model ideally fits, as the data illustrated by the following Goodness-of-Fit indices in Fig. 1; (CMIN)=144.096 (df=62), relative χ^2 (CMIN/df)=2.324, AGFI=0.931, GFI=0.953, IFI=0.968, NFI=0.945, TLI=0.959, RMSEA=0.054 and p=0.000. The model has successfully met the minimum required criteria of indices of Goodness-of-fit proposed by the various scholars (Armenta et al., 2013). Finally, the level of social capital was enumerated through mean scores of selected variables. Further distribution was made on the frequency of farmers for the particular variable. In the end, the mean score of construct variables (trust, group solidarity and networking) combined to

Table 1 Dimensions of social capital in theoretical perspective

Dimension or Type of Social Capital	Definition	Operational Variables	Direction	Sources
Structural	Overall pattern of connection (morphology or network configurations) between actors	Density, connectivity, hierarchy, solidarity	Horizontal (within a group or community)	Nahapiet and Ghoshal, (1998)
Relational	The kind of personal relationships developed through interactions	Respect, friendship, trust, norms, expectations, reciprocity, identity	Horizontal (within a group or community)	Nahapiet and Ghoshal, (1998)
Cognitive	Ability of actors to expand mutually interpretive frameworks based on language, codes and narratives	Shared interests, communication, information, informal interaction	Horizontal (within a group or community)	Nahapiet and Ghoshal, (1998)
Bonding	Involves closed networks and describes strong ties within homogeneous groups	Trust, reciprocity, norms, expectations, uniformity	Horizontal (within a group or community)	Putnam, (1993)
Bridging	Over lie system where a member of one community right to use the resources of another community through overlapping membership	Membership frequency and extent of relationship with other communities	Horizontal (individual to other groups)	Putnam, (1993)
Linking	Connections between individuals and groups in the hierarchy or power-based relationships	The extent of relationship with number of institutions and formal organizations	Vertical (Individual to formal organizations)	Woolcock, (2001)

Source: Sheikh et al. (2015a)

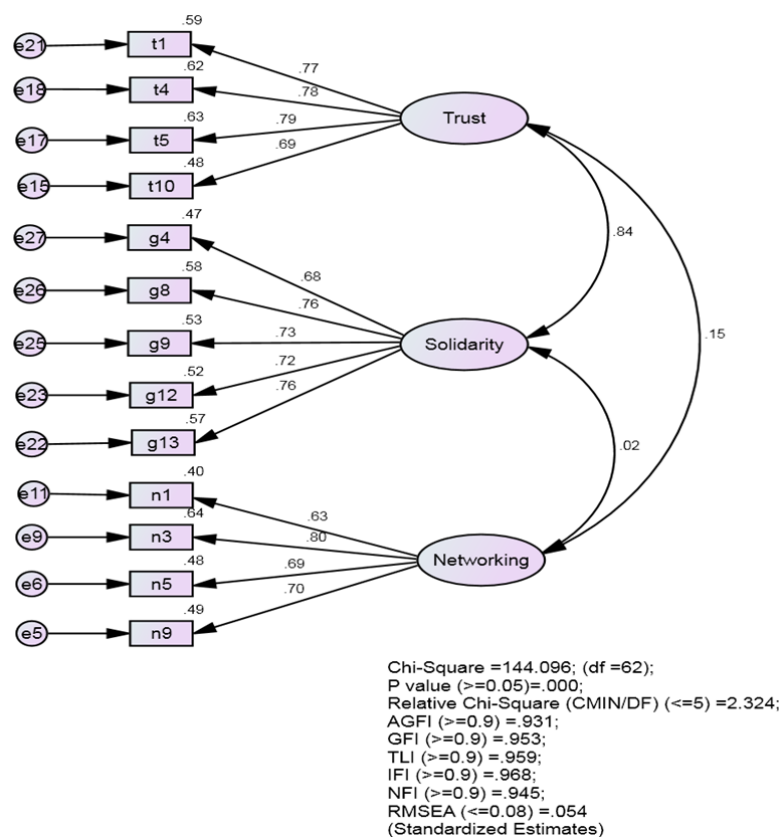

Figure 1 Correlation of social capital through CFA

latent variable to measure the farmers’ level of social capital among their communities in Sindh province of Pakistan.

The correlated factors were found within the prescribed limit. However, the factors “trust” and “group solidarity” of social capital have 0.84; close enough to an upper limit of correlation. In this regard, Wheelless et al. (1982) argued that trust and group solidarity is sensibly linked to each other, therefore, higher the solidarity indicates higher the trust among the members of a community and vice versa.

4. RESULTS AND DISCUSSION

The results indicate in Fig. 2 that the majority of farmers had medium (55%) to low (41%) level of trust with each other. In the same way, Brisson and Usher (2005) reported medium

level of bonding social capital among the participants, but claimed high levels of social capital as second majority. He is of the opinion that the homogeneity among the community members is a vital reason for the low variation in bonding social capital. Zhang et al. (2011) also reported medium level of bonding social capital among the members of various volunteer organizations in the United States. In this study, the researchers observed the bonding social capital through “trust” that is primarily used for “reciprocity” of water and other agricultural implements among the farming communities. The level of reciprocity between farmers was seen by more than the average magnitude because selling of water is considered as “taboo” among them. Therefore, the farming communities rather prefer to give their share of water to the needy person, if the person is ready to return the same amount of

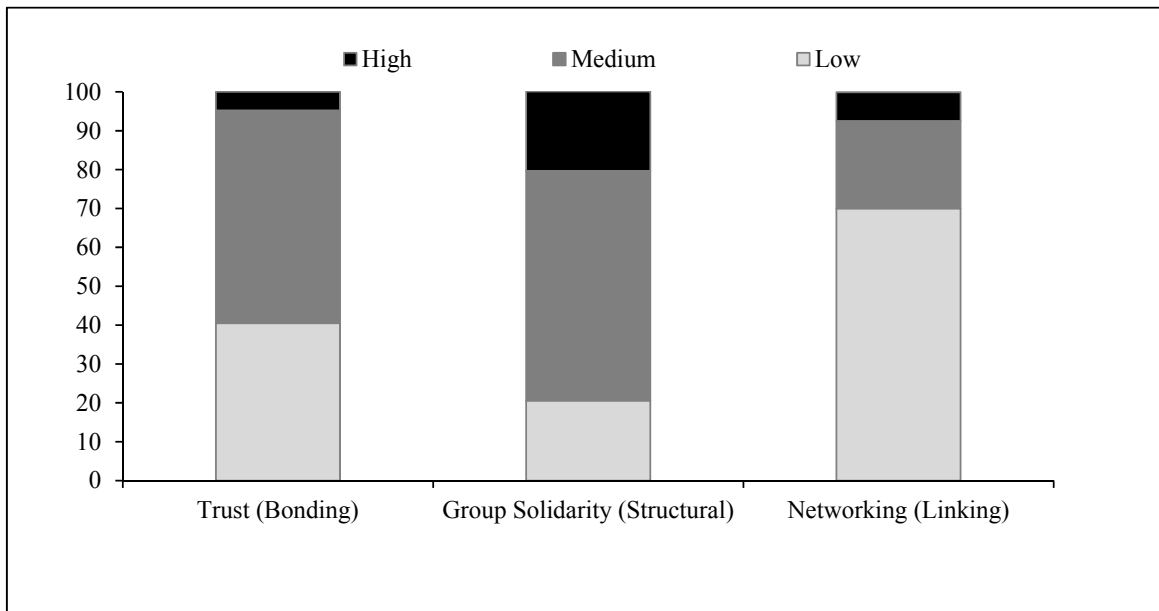

Figure 2 Level of social capital among farmers

water at his turn or a suitable time. This phenomenon was found usual in selected territories of Sindh and the norm of reciprocity takes place between the farmers at individual level based on their level of trust, which also shows a great implication of social exchange (Thibault and Kelley, 1952) in rural Sindh. But some of the landlords or rich farmers do not value to this norm of reciprocity and rely on an alternate source of irrigation water like tube wells during the scarcity.

Likewise, the group solidarity (structural social capital) of the farmers-run-association was medium (59%) too low (21%). It was revealed that the increased level of social cohesion would be achieved by utilizing the collective opportunities (Graves and Elizabeth, 2013). In addition, group solidarity and trust are closely related to each other and higher the solidarity is a simple sign of the identical trust level (Wheless et al., 1982). Obviously, in the initial extracted results under bottom-up or collaborative approaches to water management, people engage in both activities simultaneously, somehow at the same level (Sabatier et al.,

2005). Concurrently, an encouraging level of unity for accomplishing collective nature of activities was observed in a majority of the selected watercourse associations. In this regard, they develop laws, rules and values, and practice sanctions in case of breaching such values. Even though it was claimed by the majority of the farmers, but some irregularities were also observed by the researcher in the form of lack of interests in combined efforts.

By calculating the mean score of networking, which was generated as a result of participation in water management of farming communities, the researcher sought to find out the level of linking social capital. The results of the study presented in Fig. 2, shows that the majority of the respondents had low (70%) to medium (22%) level of linkages with the outer world. The results show that the community members rarely share their contacts with each other; therefore they get low to medium level of networks with formal or public institutions of the area. Anderies et al. (2004) posit that the linking social capital between resource users and public institutions is a key variable that

supports socio-ecological systems but is frequently ignored. Furthermore, the communities were severely lacking networks with governmental institutions; however, some individuals had a certain level of connections with governmental and non-governmental organizations. For this purpose, some of the respondents asked the researcher to share his cell number, which is a golden opportunity they don't want to miss in developing networks.

The communities in community development perspective are distinct by the social capital they have and are basically required for a collective action. In this study, bonding social capital, structural social capital and linking social capital were observed to identify the overall social capital level in farming communities of Sindh province of Pakistan. An aggregation of the variables shows that the majority of the respondents had medium (50%) to low (49%) level of social capital. Similarly, Khasankhanova (2003) conducted a study in Uzbekistan and also reported medium to low social capital level among the water users' associations. In Kazakhstan and Kyrgyzstan, it remained as low as possible because water users' association decision-making was dominated by local government structures.

An increased level of social capital can facilitate community members to improve their ability to address water issues efficiently (Ghazouani et al., 2012), but the situation with regard to linking social capital is quite discouraging, which may hinder sustainable development in the study area. Since, linking social capital is helpful to solve agricultural related problems and adoption of innovations for the farming communities, and then it is advised to the concerned departments that there is need to activate themselves for greater networking with farmers. However, trust and solidarity within farmer groups for water management is found satisfactory, which shows that the majority of the farmers' groups prefer to live in joint venture rather to follow

individualism. Furthermore, some of the farming communities had remarkably high unity in water management that may be further utilized by launching community development projects. But as a whole, there is needed to boost their relationships because most of the communities had medium to low level of bonding and structural social capital. Once overall social capital is promoted at cheering level, it is expected that not only irrigation water issues will be solved but the other farming matters could also be resolved on self-help basis and an actual and nonstop prosperity may be achieved.

CONCLUSIONS

The study concludes that the social capital plays an important role in achieving collective goals, thus, the agricultural benefits are positively associated with social capital. Accordingly, the result of the research reveals significant level of social capital among the studied farming communities; therefore the reciprocity of irrigation water is commonly practiced by the respondents. On the contrary, farmers were severely lacking networks (linking social capital) which must be reviewed by the authorities and policymakers, if they want rural development through water management because linkages provide positive socio-ecological changes. Although, bonding and structural social capital is reasonably lies in between the farmers, but could be further enhanced through mobilization that may boost up peace, harmony and progress in the rural economy of Sindh province of Pakistan. Finally, the research also proposed a study to be conducted in which the relationship of social capital between participation and empowerment may be clearly unveiled.

REFERENCES

- Anderies, J.M., Janssen, M.A. and Ostrom, E. (2004). A framework to analyze the robustness of social-ecological systems from an institutional perspective. *Ecology and Society*, 9(1), 1-18.
- Armenta, B.E., Lee, R.M., Pituc, S.T., Jung, K.R., Park, I.J., Soto, J.A., Kim, S.Y. and Schwartz, S.J. (2013). Where are you from? A validation of the Foreigner Objectification Scale and the psychological correlates of foreigner objectification among Asian Americans and Latinos. *Cultural Diversity and Ethnic Minority Psychology*, 19(2), 131-142.
- Bengtsson, Z. (2010). *Social Capital among Farmer Association members and non-members - a field study on inter-and intragroup trust in rural Mozambique, Lund, Sweden*. Department of Political Science, LUND University, Sweden.
- Benham, C.F., Hussey, K.E. and Beavis, S.G. (2012). *Water and Climate: Policy Implementation Changes*. The second Practical Responses to Climate Change conference, 1-3 May, Canberra, Australia.
- Berzina, K. (2011). Enterprise Related Social Capital: Different Levels of Social Capital Accumulation. *Economics and Sociology*, 4(2), 66-83.
- Brown, T.A. and Michael, T.M. (2010). *Confirmatory Factor Analysis*. Boston University, Boston, USA.
- Brisson, D.S. and Usher, C.L. (2005). Bonding Social Capital in Low-Income Neighborhoods. *Family Relations*, 54(5), 644-653.
- Castagna, A., Colantonio, E. and Furia, D. (2012). Social capital and industrial district development: the role of the local government. *Economic Science Series*, 21(1), 284-289.
- Christoforou, A. (2013). On the identity of social capital and the social capital of identity. *Cambridge Journal of Economics*, 37(4), 719-736.
- Coleman, J.S. (1988). Social Capital in the Creation of Human Capital. *The American Journal of Sociology*, 94 (Supplement 1), 95-120.
- Dahal, G.R. and Krishna, P.A. (2008). *Bridging, linking, and bonding social capital in collective action: The Case of Kalahan Forest Reserve in the Philippines, Washington*. International Food Policy Research Institute, Washington, USA.
- Darlington, R.B. (2002). *Factor Analysis*. Available at <http://comp9.psych.cornell.edu/Darlington/factor.htm> (Accessed on Jul. 24, 2002).
- De Silva, M.J., Harpham, T., Huttly, S.R., Bartolini, R. and Penny, M.E. (2007). Understanding sources and types of social capital in Peru. *Community Development Journal*, 42(1), 19-33.
- Dietlind, S. and Hooghe, M. (2003). The Sources of Social Capital: Generating Social Capital: Civil Society and Institutions in Comparative Perspective. *Business and Economics*, 288, 19-27.
- Dufur, M.J., Parcel, T.L. and Troutman, K.P. (2013). Does capital at home matter more than capital at school? Social capital effects on academic achievement. *Research in Social Stratification and Mobility*, 31(1), 1-21.
- Eklinder-Frick, J., Eriksson, L.T. and Hallén, L. (2012). Effects of social capital on processes in a regional strategic network. The impact of globalization on networks. *Industrial Marketing Management*, 41(5), 800-806.
- Evelyne, K. and Franzel, S. (2014). Voluntarism as an investment in human, social and financial capital: evidence from a farmer-to-farmer extension program in Kenya. *Agriculture and Human Values*, 31(2), 231-243.
- FAO. (2003). *Sindh Water Resources Management-Issues and Options*. Investment Centre Division, Rome, Italy.
- Fukuyama, F. (2001). Social Capital, civil society and development. *Third World Quarterly*, 22(1), 7-20.
- Gertler, P., Levine, D.I. and Moretti, E. (2006). Is Social Capital the Capital of the Poor? The Role of Family and Community in Helping Insure

- Living Standards against Health Shocks. *CESifo Economic Studies*, 52(3), 455-499.
- Ghazouani, W., Molle, F., and Rap, E. (2012). *Water Users Associations in the NEN Regions*. IFAD, Rome, Italy.
- Giorgas, D. (2007). The Significance of Social Capital for Rural and Regional Communities. *Rural Society*, 17(3), 206-214.
- Graves, E. and Elizabeth, S. (2013). *The Social Impact of Home Rehabilitation in Low-Income Neighborhoods*. Federal Reserve Bank, Boston, USA.
- Grootaert, C. and Bastelaer, T.V. (2002). *The Role of Social Capital in Development: An Empirical Assessment*. Cambridge University Press, Cambridge, UK.
- Hawkins, R.L. and Maurer, K. (2012). Unravelling Social Capital: Disentangling a Concept for Social Work. *British Journal of Social Work*, 42(2), 353-370.
- Howgate, O.R. and Kenyon, W. (2009). Community Cooperation with Natural Flood Management: A Case Study in the Scottish Borders. *Area*, 41(3), 329-340.
- Jackson, K. (2013). Contract Enforceability and the Evolution of Social Capital. *Journal of Law Economics and Organization*, 29(1), 60-77.
- Jochum, V. (2003). *Social Capital: Beyond the Theory*. National Council for Voluntary Organizations, London, UK.
- Kenny, D.A. (2012). *Multiple Latent Variable Models: Confirmatory Factor Analysis*. Available at <http://davidakenny.net/cm/mfactor.htm> (Accessed on 1999).
- Kenny, S. (2010). *Developing Communities for The Future*. Cengage Learning press, South Melbourne, Victoria, Australia.
- Khasankhanova, G. (2003). *Public participation to improve water resource management in uzbekistan*. Diffuse Pollution Conference, 17-21 August, Dublin, Ireland.
- Klein, C. (2013). Social Capital or Social Cohesion: What Matters For Subjective Well-Being? *Social Indicators Research*, 110(3), 891-911.
- Kugelman, M. and Hathaway, R.M. (2009). *Running on Empty: Pakistan's Water Crisis*. Woodrow Wilson International Center, Washington, USA.
- Leana, C.R. and Buren, H.J. (1999). Organizational social capital and employment practices. *Academy of Management Review*, 24(3), 538-555.
- Mačerinskienė, I. and Aleknavičiūtė, G. (2011). The evaluation of social capital benefits: enterprise level. *Business, Management and Education*, 9(1), 109-126.
- Magsi, H. and Torre, A. (2012). Social network legitimacy and Property right loopholes: Evidences from an infrastructural water project in Pakistan. *Journal of Infrastructure Development*, 4(2), 59-76.
- Marsden, D. and Oakley, P. (1998). *Evaluating social development projects*. Oxfam, Oxford, UK.
- Mohsenzadeh, M. (2011). Social Capital Influence on Production. *Interdisciplinary Journal of Contemporary Research in Business*, 3(2), 497-510.
- Nahapiet, J. and Ghoshal, S. (1998). Social Capital, Intellectual Capital, and the Organizational Advantage. *The Academy of Management Review*, 23(2), 242-266.
- Putnam, R.D. (1993). The prosperous community: Social capital and public life. *The American Prospect*, 13(35), 35-42.
- Putnam, R.D. (1995). Bowling Alone: America's Declining Social Capital. *Journal of Democracy*, 6(1), 65-78.
- Rudd, M.A. (2000). Live long and prosper: collective action, social capital and social vision. *Ecological Economics*, 34(1), 131-144.
- Sabatier, P.A., Focht, W., Lubell, M., Trachtenberg, Z., Vedlitz, A. and Matlock, M. (2005). *Swimming Upstream: Collaborative Approaches to Watershed Management*. The MIT Press, Massachusetts, USA.

- Saied, S., Magsi, H., Marri, F.M. and Rejeb, H. (2013). Under what management practices and mechanisms water resource can be considered as a public good for sustainable development in the developing countries? *Journal of Water Sustainability*, 3(1), 1-16.
- Seibert, S.E., Kraimer, M.L. and Liden, R.C. (2001). A social capital theory of career success. *Academy of Management Journal*, 44(2), 219-237.
- Shan, H., Muhajarine, N., Loptson, K. and Jeffery, B. (2014). Building social capital as a pathway to success: community development practices of an early childhood intervention program in Canada. *Health Promotion International*, 29(2), 1-12.
- Sheikh, M.J., Redzuan, M., Samah, A.A. and Ahmad, N. (2015a). Identifying Sources of Social Capital among the Farmers of the Rural Sindh Province of Pakistan. *Agricultural Economics-Czech*, 61(4), 189-195.
- Sheikh, M.J., Samah, M.R.A.A., Mangrio, M.A., and Baloch, L. (2015b). A Quantitative Survey of Water Management Issues in Rural Sindh. *The Government-Annual Research Journal of Political Science*, 4(4), 98-116.
- Thibault, J.W. and Kelley, H.H. (1952). *The Social Psychology of Groups*. John Wiley and Sons, New York, USA.
- Uphoff, N. (2001). Chapter-Understanding social capital: learning from the analysis and experience of participation. In: *Social capital: A multifaceted perspective*, D. Partha and S. Ismail (Eds.). The World Bank Publications, Washington, D.C., USA.
- Wheless, R., Wheless, V.E. and Dickson-Markman, F. (1982). Research note: The relations among social and task perceptions in small groups. *Small Group Behavior*, 13(3), 373-384.
- Woolcock, M. (2001). The place of social capital in understanding social and economic outcomes. *Isuma*, 2(1), 11-17.
- Wu, S. (2008). *Social capital in status attainment: Structural constraints and individual determinants-A multilevel analysis*. Duke University, North Carolina, USA.
- Yusoff, M.S.B. (2011). A Confirmatory Factor Analysis Study on the Medical Student Stressor Questionnaire among Malaysian medical students. *Education in Medicine Journal*, 3(1), 44-53.
- Zhang, S., Anderson, S.G. and Zhan, M. (2011). Differentiated Impact of Bridging and Bonding Social Capital on Economic Well-Being: An Individual Level Perspective. *Journal of Sociology & Social Welfare*, 38(1), 119-142.